



ROTARY COMPRESSOR

COMPRESSOR TECHNOLOGY
FOR AIR-CONDITIONING &
HEATPUMP APPLICATIONS



GLOBAL NETWORK

Changwon, Korea

· Address 76 Seongsan-dong, Changwon City Gyeongnam,
51554, South Korea
· Phone +82-55-269-3868
· Fax +82-55-268-4896

Tianjin, China

· Address LG Electronics(Tianjin) appliances Co., Ltd
Xing Dian Rd. Bei Chen Dist., Tianjin, China
· Phone +86-22-2690-3309
+86-22-2690-3542

Rayong, Thailand

· Address LG Electronics(Thailand) Co., Ltd
192 Moo 1, Pluakdaeng Rd.
Tambon Tasith, Ampur Pluakdaeng, Rayong 21140
· Phone +66-038-923-105
+66-038-923-119

Website <https://www.lg.com/global/business/compressor-motor>

Noida, India

· Address LG Electronics India Pvt. Ltd,
Plot No.51, Udyog Vihar,
Surajpur – Kasna Road,
Greater Noida,
Uttar Pradesh, India – 201308
· Phone +91-12-0718-0528
+91-12-0718-0100

Monterrey, Mexico

· Address Av Industrias 180, Kronos, 66603
Cdad. Apodaca, N.L., Mexico
· Phone +52-81-8196-5500

For continual product development, LG reserves the right to change specifications without notice.
© LG Electronics Inc. Printed in Korea. Feb, 2024



Revolutionary energy technologies of the future

LG COMPONENT SOLUTIONS

LG
COMPONENT
SOLUTIONS

COMPRESSOR

MOTOR

Innovation doesn't happen overnight. Ever since we built our very first fan motors in 1962, LG Compressor & Motor has been improving the lives of consumers and businesses alike. For over 60 years, we have been innovating products such as linear compressors, DD motors, scroll compressors, and R1 compressors.

As a business division under LG Electronics, LG Compressor & Motor offers excellent performance and energy efficiency for appliances in refrigeration, air conditioning, and mobility, with sustainable component solutions that meet the latest regulations and standards.

However, we don't just stop there.

We have introduced these technologies by manufacturing products built on our decades of technological advancements. That way our customers - manufacturers and product installers - can make a positive difference in the lives of their customers - the end users.

By transitioning to eco-friendly refrigerants and launching high-efficiency products for our LG Compressor & Motor component solutions, we're able to satisfy more diverse customer needs and pave the way towards an energy future that is more sustainable.

Tailored Solutions Based on a Global Network

Headquartered in South Korea, LG Component Solutions operates production facilities and sales offices in 11 cities and 6 countries around the globe. These various locations fully support our customers in over 50 countries.

LG Component Solutions aims to grow side-by-side with our customers' businesses through ongoing technical consulting for product development, performance and quality optimization for real-world conditions. Those practices, along with a flexible supply chain that enables timely supply, is fueling our commitment to be a trusted partner in the industry.



 **PRODUCTION SITE**

- Korea Changwon
- China Taizhou
- Tianjin
- Nanjing
- Qinhuangdao
- India Noida
- Thailand Rayong
- Mexico Monterrey

 **SALES OFFICE SITE**

- USA Atlanta, Dallas
- India Delhi
- Thailand Rayong
- China Qinhuangdao, Tianjin, Taizhou, Shunde
- Korea Seoul, Changwon
- Germany Frankfurt



Technical Support



Real-world Quality



Flexible Supply Chain



Long-term Partnership

Contents

LG Component Solutions	02
Sales Office / Production Site	04



New LG Rotary Compressor for Dehumidifier

LG Rotary Compressor

Product Range	08
Nomenclature	09
Specification	
- for Air Conditioner (R32 / R410A / R22)	10
- for T3 Air Conditioner (R410A / R22)	14
- for Dehumidifier (R134a)	16
- for Dryer and AWHP (R290)	17
- for Unitary in US Market (R410A / R454B)	18
Test Condition	18
Specification for Drive	20
Outline Drawing for Drive	21
Accessory Parts for Drive	21
Outline Drawing	
- for Variable Speed Model	22
- for Fixed Speed Model	28
Accessory Parts	34

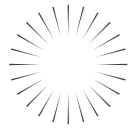

Product Range

For Air Conditionings and Heatpumps

Refrigerant	Speed	Cylinder Type	Cooling Capacity													
			kW (kBtu/hr)													
			2.0 (6.8)	3.0 (10.2)	4.0 (13.6)	5.0 (17.1)	6.0 (20.5)	7.0 (23.9)	8.0 (27.3)	9.0 (30.7)	10.0 (34.1)	11.0 (37.5)	12.0 (40.9)	13.0 (44.4)	14.0 (47.8)	15.0 (51.2)
R32	Fixed	Single	[Bar chart showing capacity range from 2.0 to 8.0 kW]													
	Variable	Single	[Bar chart showing capacity range from 3.0 to 4.0 kW]													
		Twin	[Bar chart showing capacity range from 2.0 to 14.0 kW]													
R410A	Fixed	Single	[Bar chart showing capacity range from 2.0 to 10.0 kW]													
		Twin	[Bar chart showing capacity range from 9.0 to 12.0 kW]													
	Variable	Single	[Bar chart showing capacity range from 3.0 to 4.0 kW]													
		Twin	[Bar chart showing capacity range from 2.0 to 14.0 kW]													
R22	Fixed	Single	[Bar chart showing capacity range from 4.0 to 8.0 kW]													

For Dehumidifier

Refrigerant	Speed	Cylinder Type	Cooling Capacity			
			kW (kBtu/hr)			
			1.0 (3.4)	2.0 (6.4)	3.0 (10.2)	4.0 (13.6)
R134a	Fixed	Single	[Bar chart showing capacity range from 1.0 to 2.0 kW]			
	Variable	Twin	[Bar chart showing capacity range from 2.0 to 3.0 kW]			

For Dryer and AWHP

Refrigerant	Speed	Cylinder Type	Cooling Capacity			
			kW (kBtu/hr)			
			1.0 (3.4)	2.0 (6.4)	3.0 (10.2)	4.0 (13.6)
R290	Fixed	Single	[Bar chart showing capacity range from 2.0 to 3.0 kW]			
	Variable	Twin	[Bar chart showing capacity range from 2.0 to 4.0 kW]			

For Unitary Air Conditioning

Refrigerant	Speed	Cylinder Type	Cooling Capacity													
			kW (kBtu/hr)													
			2.0 (6.8)	3.0 (10.2)	4.0 (13.6)	5.0 (17.1)	6.0 (20.5)	7.0 (23.9)	8.0 (27.3)	9.0 (30.7)	10.0 (34.1)	11.0 (37.5)	12.0 (40.9)	13.0 (44.4)	21.0 (71.7)	
R454B	Fixed	Single	[Bar chart showing capacity range from 2.0 to 10.0 kW]													
	Variable	Twin	[Bar chart showing capacity range from 7.0 to 12.0 kW]													
R410A	Fixed	Single	[Bar chart showing capacity range from 5.0 to 8.0 kW]													
	Variable	Twin	[Bar chart showing capacity range from 7.0 to 13.0 kW]													



Nomenclature

P S T 102 M A A

Refrigerant

D : R32 P : R290
 E : R134a K : R454B
 G : R410A Q : R22

Compressor size (mm)

X : Φ 80 J : Φ 122
 S : Φ 90 V : Φ 132
 A : Φ 101 P : Φ 139
 K : Φ 112

Generation code

(A - Z)
 A : for Unitary R : Horizontal
 T : Twin

Capacity

Displacement
 (ex : 141 = 14.1 cc/rev)

Exterior specification

(A - Z)

Motor specification

(A - Z)

Motor code

Code	Power		
	Phase (Φ)	Voltage (V)	Frequency (Φ)
C	1	115	60
K	1	208 ~ 230	60
P	1	220 / 240	50
Q	1	265	60
M	3	DC Inverter	-

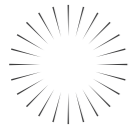

Specification for Air Conditioner [1/3]

Variable Speed R32

Cylinder Type	Series	Model	Test Condition	Cooling Capacity		Input Watts	EER Btu/W-hr	COP W/W	Drawing No.	Outline Page	
				Btu/hr	Watts						
Single	DSG	DSG075MD	ASHRAE	8,515	2,496	760	11.2	3.3	DSG-A	p.22	
		DSG075ME	ASHRAE	8,150	2,389	721	11.3	3.3	DSG-A	p.22	
		DSG075MG	ARI	8,000	2,345	777	10.3	2.9	DSG-A	p.22	
		DSG102MC	SET	11,363	3,330	773	14.7	4.3	DSG-A	p.22	
		DSG102MM	SET	11,100	3,253	771	14.4	4.2	DSG-B	p.22	
Twin	DXT	DXT075MA	SET	10,300	3,019	606	17.0	5.0	DXT	p.22	
		DXT102MA	SET	13,700	4,015	801	17.1	5.0	DXT	p.22	
	DST	DST066MA	ASHRAE	7,200	2,110	655	11.0	3.2	DST-A	p.23	
		DST075MA	ASHRAE	8,475	2,484	770	11.0	3.2	DST-A	p.23	
		DST102MA	ASHRAE	11,400	3,341	1,036	11.0	3.2	DST-A	p.23	
		DST134MB	ARI	14,700	4,308	1,393	10.5	3.1	DST-B	p.23	
		DST156MA	ARI	17,065	5,000	1,605	10.6	3.1	DST-B	p.23	
	DAT	DAT134MC	ARI	14,535	3,941	1,320	11.0	3.2	DAT	p.24	
		DAT156MA	ARI	17,400	5,100	1,582	11.0	3.2	DAT	p.24	
	DKT	DKT	DKT141MB	ARI	15,400	4,513	1,403	11.0	3.2	DKT-A	p.25
			DKT176MA	ARI	19,500	5,715	1,780	11.0	3.2	DKT-B	p.25
			DKT176MD	ARI	19,850	5,818	1,741	11.4	3.3	DKT-C	p.25
			DKT208MA	ARI	23,400	6,857	2,127	11.0	3.2	DKT-B	p.25
			DKT208MC	ARI	23,550	6,902	2,141	11.0	3.2	DKT-C	p.25
			DKT240MA	ARI	26,200	7,679	2,472	10.6	3.1	DKT-D	p.26
			DKT240MB	ARI	27,250	7,986	2,500	10.9	3.2	DKT-D	p.26
			DJT	DJT240MA	ARI	26,900	7,884	2,402	11.2	3.3	DJT-A
	DPT	DPT	DPT420MA	ARI	45,130	13,227	4,030	11.2	3.3	DJT-B	p.26
			DPT330MA	SET	48,200	14,127	2,758	17.5	5.1	DPT-V	p.27
			DPT442MA	ARI	50,500	14,799	4,510	11.2	3.3	DPT-V	p.27
DPT442MB			ARI	50,760	14,877	4,615	11.0	3.2	DPT-V	p.27	
		DPT442MC	ARI	50,300	14,740	4,710	10.7	3.1	DPT-V	p.27	

Variable Speed R410A

Cylinder Type	Series	Model	Test Condition	Cooling Capacity		Input Watts	EER Btu/W-hr	COP W/W	Drawing No.	Outline Page	
				Btu/hr	Watts						
Twin	GST	GST102MA	SET	12,620	3,699	770	16.4	4.8	GST-A	p.23	
		GST066MA	SET	7,950	2,330	497	16.0	4.7	GST-A	p.23	
		GST075MA	ASHRAE	8,178	2,397	743	11.0	3.2	GST-A	p.23	
		GST134MB	ARI	13,380	3,921	1,275	10.5	3.1	GST-B	p.23	
		GST156MA	ARI	15,650	4,615	1,485	10.6	3.1	GST-B	p.23	
	GAT	GAT	GAT134MC	ARI	13,500	3,957	1,220	11.1	3.2	GAT	p.24
			GAT156MA	ARI	15,752	4,617	1,446	10.9	3.2	GAT	p.24
			GAT156MC	ARI	15,770	4,622	1,440	11.0	3.2	GAT	p.24
	GKT	GKT	GKT141MB	ARI	14,600	4,279	1,327	11.0	3.2	GKT-A	p.25
			GKT176MA	ARI	18,800	5,510	1,700	11.1	3.2	GKT-B	p.25
			GKT176MB	ARI	18,800	5,510	1,694	11.1	3.3	GKT-B	p.25
			GKT208MA	ARI	22,200	6,506	2,018	11.0	3.2	GKT-B	p.25
	GJT	GJT	GJT240MA	ARI	25,300	7,415	2,280	11.1	3.3	GJT-A	p.26
			GPT330MA	ARI	35,200	10,317	3,129	11.2	3.3	GPT-V	p.27
	GPT	GPT	GPT442MA	ARI	47,500	13,921	4,241	11.2	3.3	GPT-V	p.27



Specification for Air Conditioner [2/3]

Fixed Speed R32

1Φ – 60 Hz – 115 V

Cylinder Type	Series	Model	Test Condition	Cooling Capacity		Input Watts	EER Btu/W-hr	COP W/W	Drawing No.	Outline Page
				Btu/hr	Watts					
Single	DAB	DAB065CA	LW	7,480	2,190	615	12.2	3.6	DAB	p.28
		DAB080CA	LW	9,238	2,707	764	12.1	3.5	DAB	p.28
	DKS	DKS108CA	LW	11,800	3,458	968	12.2	3.6	DKS-A	p.29
		DKS126CA	LW	13,980	4,097	1,187	11.8	3.5	DKS-A	p.29

Fixed Speed R32

1Φ – 60 Hz – 208 ~ 230 V

Cylinder Type	Series	Model	Test Condition	Cooling Capacity		Input Watts	EER Btu/W-hr	COP W/W	Drawing No.	Outline Page
				Btu/hr	Watts					
Single	DAB	DAB065KA	ARI	6,650	1,949	686	9.7	2.8	DAB	p.28
		DAB080KA	LW	9,300	2,725	780	11.9	3.5	DAB	p.28
	DKN	DKN127KA	ARI	13,020	3,816	1,385	9.4	2.8	DKN-A	p.29
		DVH151KA	LW	17,920	5,252	1,400	12.8	3.8	DVH	p.31
	DVH	DVH218KA	LW	27,050	7,928	2,041	13.3	3.9	DVH	p.31

Fixed Speed R32

1Φ – 50 Hz – 220 / 240 V

Cylinder Type	Series	Model	Test Condition	Cooling Capacity		Input Watts	EER Btu/W-hr	COP W/W	Drawing No.	Outline Page	
				Btu/hr	Watts						
Single	DKN	DKN127PA	ARI	10,800	3,165	1,113	9.7	2.8	DKN-B	p.29	
		DKN141PA	ARI	12,100	3,546	1,287	9.4	2.8	DKN-B	p.30	
	DJS	DJS165PA	ARI	14,000	4,103	1,458	9.6	2.8	DJS	p.30	
		DJS189PA	ARI	15,700	4,601	1,602	9.8	2.9	DJS	p.30	
		DJS230PA	ARI	19,350	5,671	1,995	9.7	2.8	DJS	p.30	
	DVH	DVH240PA	ARI	20,850	6,111	2,060	10.1	3.0	DVH	p.31	
		DVS	DVS295PA	ARI	25,500	7,473	2,630	9.7	2.8	DVS	p.32
				DVS325PA	ARI	28,000	8,205	2,995	9.35	2.7	DVS

Fixed Speed R410A

1Φ – 60 Hz – 115 V

Cylinder Type	Series	Model	Test Condition	Cooling Capacity		Input Watts	EER Btu/W-hr	COP W/W	Drawing No.	Outline Page
				Btu/hr	Watts					
Single	GA	GA066CA	ASHRAE	6,500	1,905	677	9.6	2.8	GA	p.28
		GAB045CB	LW	5,035	1,476	408	12.4	3.6	GAB	p.28
	GAB	GAB050CA	LW	5,880	1,723	446	13.2	3.9	GAB	p.28
		GAB070CB	ASHRAE	7,830	2,295	612	12.8	3.8	GAB	p.28
		GK080CA	ASHRAE	8,050	2,359	821	9.8	2.9	GK-B	p.29
	GKN	GKN102CM	ASHRAE	10,150	2,974	1,015	10.0	2.9	GKN-C	p.30
		GKN141CM	ASHRAE	13,000	3,810	1,365	9.5	2.8	GKN-C	p.30
	GKS	GKS108CB	ASHRAE	10,450	3,063	1,025	10.2	3.0	GKS-B	p.29
		GKS113CA	ASHRAE	11,200	3,283	1,098	10.2	3.0	GKS-B	p.29
		GKS134CA	ASHRAE	13,300	3,898	1,317	10.1	3.0	GKS-B	p.30
		GKS134CM	ASHRAE	13,200	3,869	1,361	9.7	2.8	GKS-C	p.30
	GJS	GJS134CA	ASHRAE	13,000	3,810	1,494	8.7	2.5	GJS-B	p.31

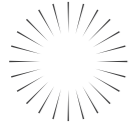

Specification for Air Conditioner [3/3]

Fixed Speed R410A

1Φ – 60 Hz – 208 ~ 230 V

Cylinder Type	Series	Model	Test Condition	Cooling Capacity		Input	EER	COP	Drawing No.	Outline Page	
				Btu/hr	Watts						
Single	GA	GA066KA	ASHRAE	6,400	1,876	667	9.6	2.8	GA	p.28	
	GAB	GAB070KA	ASHRAE	7,050	2,066	691	10.2	3.0	GAB	p.28	
	GK	GK151KA	ASHRAE	15,400	4,513	1,556	9.9	2.9	GK-B	p.30	
	GKS	GKS086KA	ASHRAE	8,750	2,564	858	10.2	3.0	GKS-B	p.29	
		GKS102KA	ASHRAE	10,000	2,931	962	10.4	3.0	GKS-B	p.29	
		GKS113KA	ASHRAE	11,250	3,297	1,103	10.2	3.0	GKS-B	p.29	
		GKS134KA	ASHRAE	13,500	3,957	1,337	10.1	3.0	GKS-B	p.30	
		GKS141KA	ASHRAE	14,100	4,132	1,396	10.1	3.0	GKS-B	p.30	
	GJ	GJ230KA	ASHRAE	24,000	7,034	2,400	10.0	2.9	GJ	p.30	
	GJS	GJS151KA	ASHRAE	15,400	4,513	1,495	10.3	3.0	GJS	p.30	
		GJS160KA	ASHRAE	15,800	4,630	1,540	10.3	3.0	GJS	p.31	
		GJS176KA	ASHRAE	18,200	5,333	1,784	10.2	3.0	GJS	p.31	
		GJS208KA	ASHRAE	20,800	6,096	2,019	10.3	3.0	GJS	p.30	
	GVS	GVS215KA	ASHRAE	22,300	6,536	2,180	10.2	3.0	GVS	p.32	
		GVS265KA	ASHRAE	27,750	8,133	2,670	10.4	3.1	GVS	p.32	
	Twin	GPT-F	GPT342KA	ASHRAE	35,770	10,482	3,614	9.9	2.9	GPT-F	p.33
			GPT362KA	ASHRAE	38,200	11,194	3,782	10.1	3.0	GPT-F	p.33

Fixed Speed R410A

1Φ – 60 Hz – 265 V

Cylinder Type	Series	Model	Test Condition	Cooling Capacity		Input	EER	COP	Drawing No.	Outline Page
				Btu/hr	Watts					
Single	GA	GA066QA	ASHRAE	6,350	1,861	661	9.6	2.8	GA	p.28
	GK	GK080QA	ASHRAE	8,350	2,447	852	9.8	2.9	GK-B	p.29
		GK151QA	ASHRAE	15,400	4,513	1,525	10.1	3.0	GK-B	p.30
	GKS	GKS086QA	ASHRAE	8,800	2,579	846	10.4	3.0	GKS-B	p.29
		GKS102QA	ASHRAE	10,150	2,975	976	10.4	3.0	GKS-B	p.29
		GKS113QA	ASHRAE	11,250	3,297	1,103	10.2	3.0	GKS-B	p.29
		GKS120QA	ASHRAE	12,100	3,546	1,175	10.3	3.0	GKS-B	p.29
		GKS141QA	ASHRAE	14,200	4,162	1,406	10.1	3.0	GKS-B	p.30
	GJS	GJS176QA	ASHRAE	17,700	5,188	1,735	10.2	3.0	GJS	p.30
	GVS	GVS295QM	ASHRAE	30,100	8,822	2,951	10.2	3.0	GVS	p.32

Fixed Speed R410A

1Φ – 50 Hz – 220 / 240 V

Cylinder Type	Series	Model	Test Condition	Cooling Capacity		Input	EER	COP	Drawing No.	Outline Page
				Btu/hr	Watts					
Single	GAB	GAB046PA	ASHRAE	4,520	1,325	455	10.0	2.91	GAB	p.28
	GKN	GKN102PA	ASHRAE	8,700	2,549	845	10.3	3.02	GKN-A	p.29
		GKN127PA	ASHRAE	10,900	3,194	1,090	10.0	2.93	GKN-A	p.29
		GKN141PA	ASHRAE	11,350	3,326	1,146	9.9	2.9	GKN-A	p.29
	GJS	GJS134PA	ASHRAE	10,120	2,966	1,150	8.8	2.58	GJS-B	p.31
		GJS208PA	ASHRAE	16,800	4,923	1,645	10.2	2.99	GJS	p.30
		GJS222PA	ASHRAE	18,800	5,509	1,825	10.3	3.02	GJS	p.30
	GVH	GVH240PA	ASHRAE	20,720	6,072	1,937	10.7	3.13	GVH	p.31
		GVH265PA	ASHRAE	22,900	6,711	2,224	10.3	3.02	GVH	p.31
	GVS	GVH282PA	ASHRAE	24,430	7,159	2,305	10.6	3.1	GVH	p.31
		GVS295PA	ASHRAE	24,950	7,312	2,495	10.0	2.93	GVS	p.32
			GVS325PA	ASHRAE	27,450	8,045	2,718	10.1	2.96	GVS

Fixed Speed R22

1Φ – 50 Hz – 220 / 240 V

Cylinder Type	Series	Model	Test Condition	Cooling Capacity		Input	EER	COP	Drawing No.	Outline Page
				Btu/hr	Watts					
Single	QJS	QJS222PM	ASHRAE	12,750	3,736	1,210	10.5	3.1	QJS	p.31
	QP	QP464PB	ASHRAE	27,800	8,148	2,574	10.8	3.2	QP	p.32

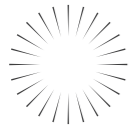

Specification for T3 Air Conditioner

Fixed Speed R410A

1Φ – 60 Hz – 208 ~ 230 V

Cylinder Type	Series	Model	Test Condition	Cooling Capacity		Input Watts	EER Btu/W-hr	COP W/W	Drawing No.	Outline Page
				Btu/hr	Watts					
Single	GJS	GJS160KB	ASHRAE	15,300	4,463	1,530	10.0	2.9	GJS	p.31
		GJS176KB	ASHRAE	17,100	5,010	1,710	10.0	2.9	GJS	p.31
	GVH	GVH198KA	ASHRAE	20,100	5,891	1,900	10.6	3.1	GVH	p.31
		GVH240KA	ASHRAE	24,850	7,283	2,368	10.5	3.1	GVH	p.31
	GVS	GVS215KB	ASHRAE	22,300	6,535	2,124	10.5	3.1	GVS	p.32

Fixed Speed R410A

1Φ – 50 Hz – 220 / 240 V

Cylinder Type	Series	Model	Test Condition	Cooling Capacity		Input Watts	EER Btu/W-hr	COP W/W	Drawing No.	Outline Page
				Btu/hr	Watts					
Single	GVH	GVH180PA	ASHRAE	15,100	4,425	1,440	10.5	3.1	GVH	p.31
		GVH250PA	ASHRAE	21,550	6,316	2,030	10.6	3.1	GVH	p.31
	GVS	GVS265PA	ASHRAE	22,850	6,696	2,210	10.3	3.0	GVS	p.32

Fixed Speed R22

1Φ – 60 Hz – 208 ~ 230 V

Cylinder Type	Series	Model	Test Condition	Cooling Capacity		Input Watts	EER Btu/W-hr	COP W/W	Drawing No.	Outline Page
				Btu/hr	Watts					
Single	QJS	QJS258KM	ASHRAE	18,600	5,451	1,777	10.5	3.1	QJS	p.31
		QJS282KA	ASHRAE	20,250	5,103	1,849	11.0	2.8	QJS	p.31
	QVS	QVS250KA	ASHRAE	18,150	5,319	1,592	11.4	3.3	QVS	p.32
		QVS348KM	ASHRAE	25,200	7,385	2,291	11.0	3.2	QVS	p.32

Fixed Speed R22

1Φ – 50 Hz – 220 / 240 V

Cylinder Type	Series	Model	Test Condition	Cooling Capacity		Input Watts	EER Btu/W-hr	COP W/W	Drawing No.	Outline Page
				Btu/hr	Watts					
Single	QVS	QVS325PA	ASHRAE	19,200	5,627	1,746	11.0	3.2	QVS	p.32
		QP407PA	ASHRAE	24,100	7,063	2,317	10.4	3.0	QP	p.32
	QP	QP442PB	ASHRAE	26,000	7,620	2,549	10.2	3.0	QP	p.32
		QP464PA	ASHRAE	27,600	8,089	2,654	10.4	3.0	QP	p.32

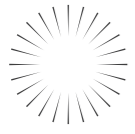

Specification for Dehumidifier

Variable Speed R134a

Cylinder Type	Series	Model	Test Condition	Cooling Capacity		Input Watts	EER Btu/W-hr	COP W/W	Drawing No.	Outline Page
				Btu/hr	Watts					
Twin	EXT	EXT102MA	ASHRAE	4,780	1,401	400	12.0	3.5	EXT	p.23
	EST	EST092MB	ASHRAE	4,550	1,333	376	12.1	3.5	EST	p.24
		EST102MB	ASHRAE	5,100	1,495	396	12.9	3.8	EST	p.24

Fixed Speed R134a

1Φ – 60 Hz – 208 ~ 230 V

Cylinder Type	Series	Model	Test Condition	Cooling Capacity		Input Watts	EER Btu/W-hr	COP W/W	Drawing No.	Outline Page
				Btu/hr	Watts					
Single	EAB	EAB086KA	ASHRAE	4,190	1,228	360	11.6	3.4	EAB	p.28
	EKS	EKS094KA	Dryer	7,250	2,124	594	12.2	3.6	EKS	p.29

Fixed Speed R134a

1Φ – 50 Hz – 220 / 240 V

Cylinder Type	Series	Model	Test Condition	Cooling Capacity		Input Watts	EER Btu/W-hr	COP W/W	Drawing No.	Outline Page
				Btu/hr	Watts					
Single	EA	EA078PA	Dryer	5,210	1,527	420	12.4	3.6	EA	p.28
		EA089PA	Dryer	6,000	1,758	480	12.5	3.7	EA	p.28



Specification for Dryer and AWHP

Variable Speed R290

Cylinder Type	Series	Model	Test Condition	Cooling Capacity		Input Watts	EER Btu/W-hr	COP W/W	Drawing No.	Outline Page
				Btu/hr	Watts					
Twin	PST	PST092MA	ASHRAE	5,680	1,664	481	11.8	3.5	PST	p.24
		PST066MA	ASHRAE	4,040	1,184	356	11.4	3.3	PST	p.24
		PST102MA	ASHRAE	6,450	1,890	531	12.1	3.6	PST	p.24
	PAT	PAT134MA	ASHRAE	8,250	2,419	697	11.8	3.5	PAT	p.24

Fixed Speed R290

1Φ – 60 Hz – 208 ~ 230 V

Cylinder Type	Series	Model	Test Condition	Cooling Capacity		Input Watts	EER Btu/W-hr	COP W/W	Drawing No.	Outline Page
				Btu/hr	Watts					
Single	PSG	PSG075KA	ASHRAE	4,660	1,366	451	10.3	3.0	PSG	p.28

Fixed Speed R290

1Φ – 50 Hz – 220 / 240 V

Cylinder Type	Series	Model	Test Condition	Cooling Capacity		Input Watts	EER Btu/W-hr	COP W/W	Drawing No.	Outline Page
				Btu/hr	Watts					
Single	PSG	PSG075PA	ASHRAE	3,714	1,088	387	9.6	2.8	PSG	p.28
		PAB065PA	ASHRAE	3,285	963	345	9.5	2.8	PAB	p.28
	PAB	PAB086PA	Dryer	6,945	2,035	610	11.4	3.3	PAB	p.28
		PA	PA125PA	ASHRAE	6,385	1,871	582	11.0	3.2	PA

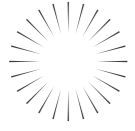

Specification for Unitary in US Market

Fixed Speed R410A

1Φ – 60 Hz – 208 ~ 230 V

Cylinder Type	Series	Model	Test Condition	Cooling Capacity		Input Watts	EER Btu/W-hr	COP W/W	Drawing No.	Outline Page
				Btu/hr	Watts					
Single	GVA	GVA153KA	ARI	15,150	4,440	1,546	9.8	2.9	GVA	p.33
			DOE-B	21,400	6,271	1,028	20.8	6.1		
		GVA198KA	ARI	19,700	5,773	1,950	10.1	3.0	GVA	p.33
			DOE-B	27,650	8,103	1,298	21.3	6.2		
		GVA202KA	ARI	20,000	5,861	2,000	10.0	2.9	GVA	p.33
			DOE-B	28,100	8,234	1,319	21.3	6.2		
	GVA236KA	ARI	23,320	6,834	2,332	10.0	2.9	GVA	p.33	
		DOE-B	33,370	9,779	1,559	21.4	6.3			
	GVA250KA	ARI	25,000	7,326	2,475	10.1	3.0	GVA	p.33	
		DOE-B	35,500	10,403	1,660	21.4	6.3			

Fixed Speed R454B

1Φ – 60 Hz – 208 ~ 230 V

Cylinder Type	Series	Model	Test Condition	Cooling Capacity		Input Watts	EER Btu/W-hr	COP W/W	Drawing No.	Outline Page
				Btu/hr	Watts					
Single	KJA	KJA104KA	ARI	10,000	2,931	936	10.7	3.1	KJA	p.33
			DOE-B	13,700	4,015	688	19.9	5.8		
		KJA151KA	ARI	14,300	4,191	1,363	10.5	3.1	KJA	p.33
			DOE-B	19,700	5,774	909	21.7	6.4		
		KJA200KA	ARI	18,900	5,539	1,784	10.6	3.1	KJA	p.33
			DOE-B	26,100	7,649	1,198	21.8	6.4		
	KVA	KVA236KA	ARI	22,800	6,682	2,132	10.7	3.1	KJA	p.33
			DOE-B	31,200	9,144	1,406	22.2	6.5		
		KVA250KA	ARI	24,100	7,063	2,232	10.8	3.2	KVA	p.33
			DOE-B	33,200	9,730	1,503	22.1	6.5		
		KVA282KA	ARI	27,500	8,060	2,547	10.8	3.2	KVA	p.33
			DOE-B	37,800	11,079	1,727	21.9	6.4		

Variable Speed R410A

Cylinder Type	Series	Model	Test Condition	Cooling Capacity		Input Watts	EER Btu/W-hr	COP W/W	Drawing No.	Outline Page
				Btu/hr	Watts					
Twin	GJT	GJT240MC	ARI@60 Hz	25,400	7,443	2,327	10.9	3.2	GJT-U	p.27
			DOE-A@70 Hz	37,120	10,878	2,350	15.8	4.6		
			DOE-B@35 Hz	19,350	5,670	843	23.0	6.7		
	GPT	GPT442MA	ARI@60 Hz	47,000	13,773	4,360	10.8	3.2	GJT-U	p.27
			DOE-A@65 Hz	63,350	18,564	4,060	15.6	4.6		
			DOE-B@35 Hz	35,800	10,491	1,555	23.0	6.8		

Variable Speed R454B

Cylinder Type	Series	Model	Test Condition	Cooling Capacity		Input Watts	EER Btu/W-hr	COP W/W	Drawing No.	Outline Page
				Btu/hr	Watts					
Twin	KJT	KJT240MC	ARI@60 Hz	23,900	7,005	2,143	11.2	3.3	KJT-U	p.27
			DOE-A@70 Hz	34,700	10,170	2,169	16.0	4.7		
			DOE-B@35 Hz	17,900	5,246	778	23.0	6.7		
	KPT	KPT442MA	ARI@60 Hz	45,000	13,189	4,018	11.2	3.3	KPT-U	p.27
			DOE-A@65 Hz	59,300	17,380	3,730	15.9	4.7		
			DOE-B@35 Hz	33,200	9,730	1,443	23.0	6.7		



Test Condition

Unit (°C)

Test condition	Evaporating Temperature	Condensing Temperature	Subcooled Temperature	Superheated Temperature	Remark
ASHRAE	7.2	54.4	8.3	27.8	
ARI	7.2	54.4	8.3	11.1	
SET	12.0	46.0	8.0	8.0	For Residential Inverter AC System
DOE-A	10.0	46.1	8.3	11.1	For North America AC System
DOE-B	10.0	37.8	8.8	11.1	For North America AC System
Dryer	23.0	71.0	24.9	12.0	For Heat Pump Dryer
LW	10.0	49.0	5.0	8.3	For Residential Non-Inverter AC System



Specification for Drive

Residential Inverter Drive

Content	Spec	1 kW	4 kW	6 kW	7 kW
Drive	1 Model name	A*01K001A	A*04K001A	A*06K001A	A*07K001A
	2 Rated Input Voltage [V]	1Φ, 208 - 230 Vac			
	3 Input Frequency [Hz]	50 - 60			
	4 Maximum Input Current [Arms]	5.5	18	27	31
	5 Maximum Input Power [W]	1,000	4,000	6,000	7,000
	6 Operating Compressor Speed [Hz]	15 ~ 90		10 ~ 120	
	7 Converter Type	HPSC	PFC		
	8 Compressor Connection Color	-	Red (U) / Blue (V) / Yellow (W)		
	9 Ambient Operating Temperature [°C]	0 ~ 40	-20 ~ 48		
	10 Storage Temperature [°C]	-40 ~ 60			
	11 Max. Storage Relative Humidity	85 %			
Reactor	1 Model name	EBJ61450001	PDR040K350	PDR060K350	TBD
	2 Rated Input Voltage [V]	1Φ, 208 - 230 Vac			
	3 Input Frequency [Hz]	50 / 60			
	4 Maximum Input Current [Arms]	6	20	25	TBD
	5 Inductance at 30 kHz, 1 Vac (25°C)	13mH	200 uH ± 15 %		TBD

Commercial Inverter Drive

Contents	Spec	7kW		
Drive	1 Model Name	A*07R101A	A*07S101A	A*07T101A
	2 Rated Input Voltage [V]	3Φ 208-230	3Φ 460	3Φ 575
	3 Input Frequency [Hz]	60		
	4 Maximum Input Current [Arms]	21	11	9
	5 Maximum Input Power [W]	7,000		
	6 Operating Compressor Speed [Hz]	15 ~ 150		
	7 Converter Type	Bridge Diode		
	8 Compressor Connection Color	Red (U) / Blue (V) / Yellow (W)		
	9 Ambient Operating Temperature [°C]	-20 ~ 48	-20 ~ 48	-20 ~ 52
	10 Storage Temperature [°C]	-40 ~ 60		
	11 Max. Storage Relative Humidity [%]	85	85	95
Noise Filter	1 Current Range [Peak Current]	50		
	2 Rated Frequency [Hz]	50 / 60		
	3 Leakage Current	6.0 mA MAX. at AC 380 V 50 / 60 Hz (R, S, T - Gnd)		
	4 Insulation Resistance	Line to Gnd, AC 1,500 V for 1 Min. (AC 1,800 V for 1 Sec.)		
	5 Operating Temperature [°C]	-40 ~ 85		
	6 Storage Temperature [°C]	-40 ~ 90		
Transformer	1 Model Name	PDR070R040	PDR070S030	PDR070T040
	2 Rated Input Voltage [V]	230	460	575
	3 Rated Input Frequency [Hz]	50 / 60	50 / 60	50 / 60
	4 Rated Output Voltage [V]	230	230	230



Outline Drawing for Drive

Residential Inverter Drive

- A*01K001

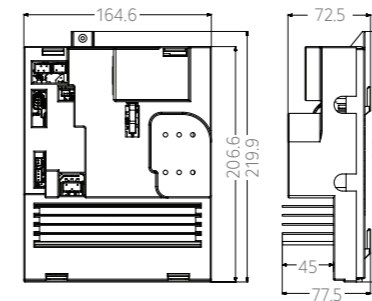

- A*04K001

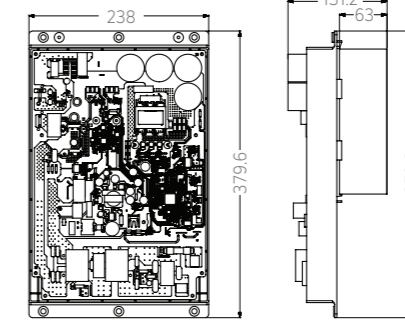

- A*06K001

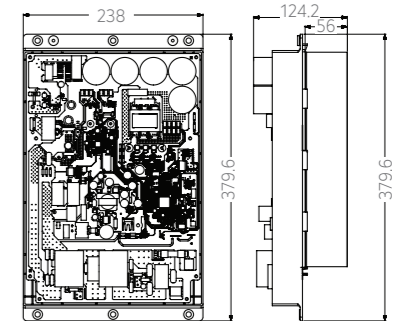

Commercial Inverter Drive

- A*07R101A

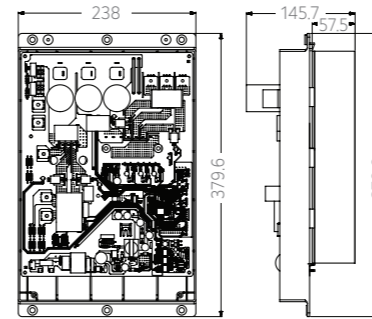

- A*07S101A

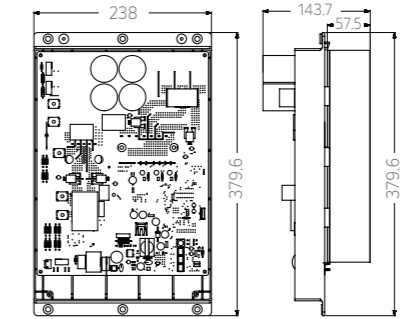

- A*07T101A

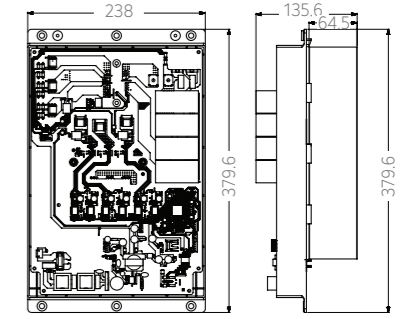

Accessory Parts for Drive



Note : 4 kW Drive has on board noise filter.

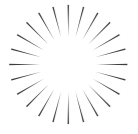

Outline Drawing for Variable Speed Model

· DSG / GSG / GS-A

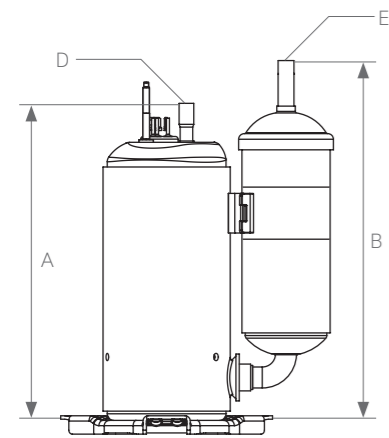
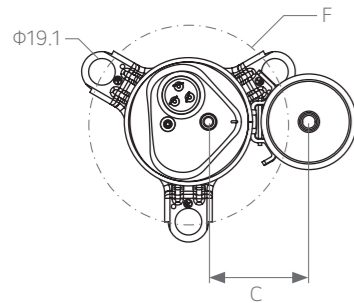

· DSG / GSG / GS-B

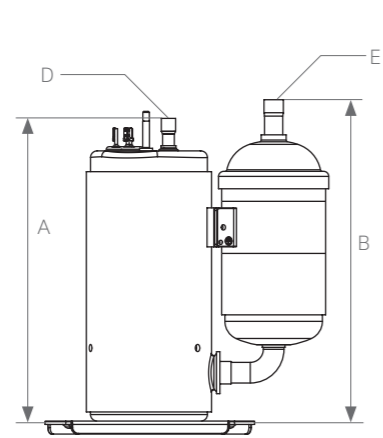
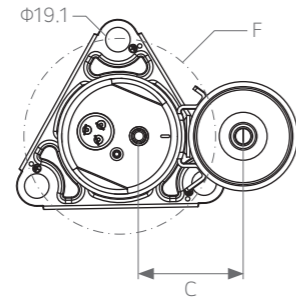

· DXT

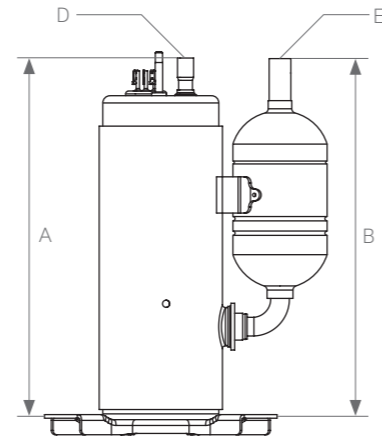
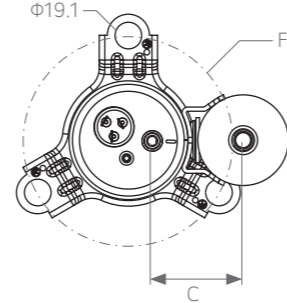

· EXT

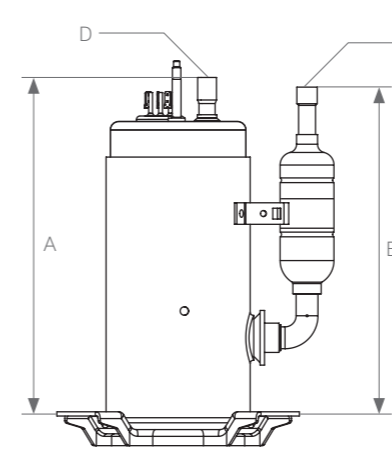
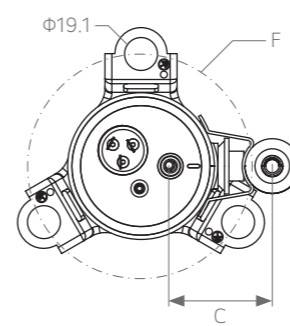

· DST / GST-A

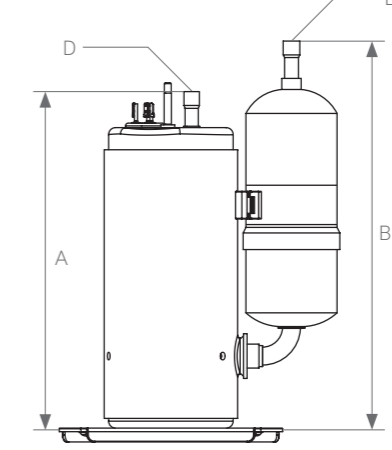
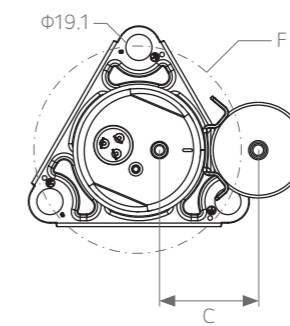

· DST / GST-B

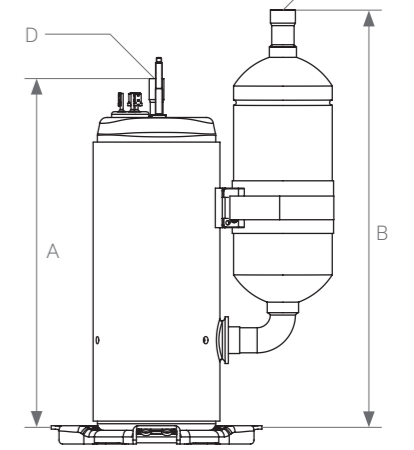
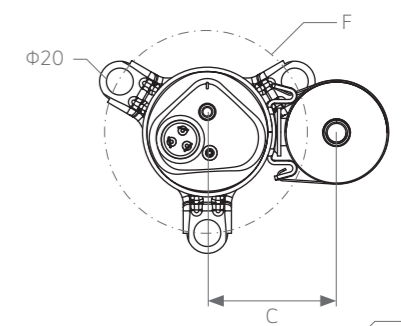

Model	Series	Dimension					
		A	B	C	D	E	F
DSG075MD	DSG-A	218.2	251.6	70.0	8.06	9.7	150
DSG075ME	DSG-A	239.2	251.6	67.6	8.06	9.7	150
DSG075MG	DSG-A	223.3	251.6	75.0	8.06	9.7	150
DSG102MC	DSG-A	258.3	284.4	76.0	8.06	9.7	150
DSG102MM	DSG-B	248.4	249.8	82.2	8.06	12.8	150
DXT075MA	DXT	213.9	233.2	62.8	8.06	9.7	150
DXT102MA	DXT	248.6	248.2	65.2	8.06	9.7	150

Model	Series	Dimension					
		A	B	C	D	E	F
EXT102MA	EXT	200.0	194.2	59.0	8.06	9.7	130
DST066MA	DST-A	220.6	222.3	72.5	8.06	9.7	150
DST075MA	DST-A	220.6	225.3	66.7	8.06	9.7	150
DST102MA	DST-A	245.6	282.1	72.5	8.06	9.7	150
DST134MB	DST-B	266.3	282.0	85.0	8.06	12.8	150
DST156MA	DST-B	276.3	339.6	81.0	8.06	12.8	150
GST102MA	GST-A	245.6	282.1	72.5	8.06	9.7	150
GST066MA	GST-A	220.6	222.3	72.5	8.06	9.7	150
GST075MA	GST-A	220.6	225.3	66.7	8.06	9.7	150
GST134MB	GST-B	266.3	282.0	85.0	8.06	12.8	150
GST156MA	GST-B	276.3	339.6	81.0	8.06	12.8	150

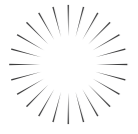

Outline Drawing for Variable Speed Model

· EST / PST

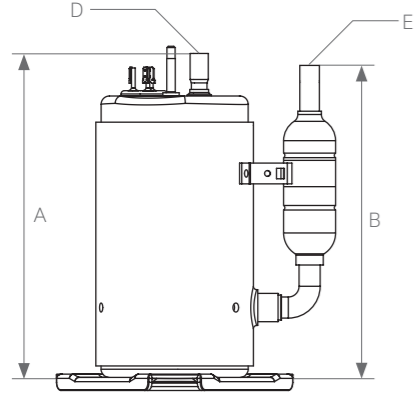
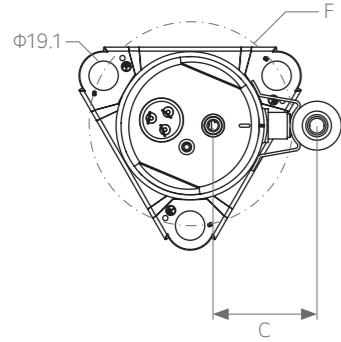

· DAT / GAT

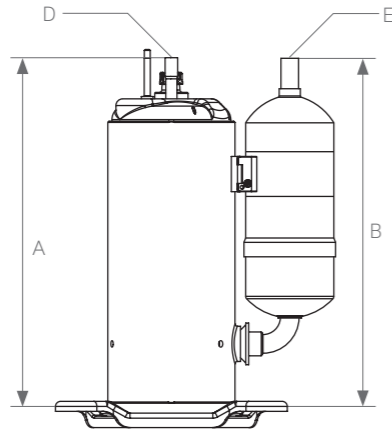
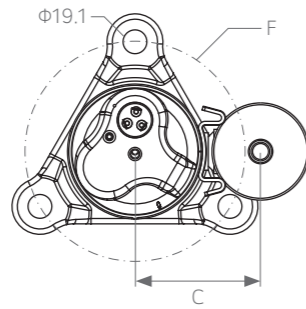

· PAT

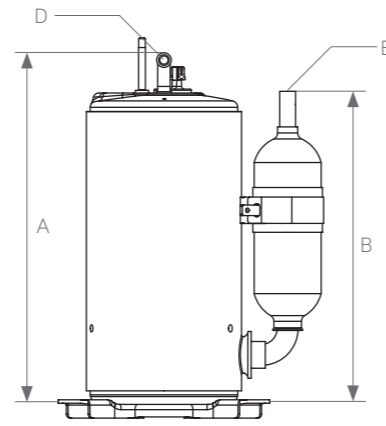
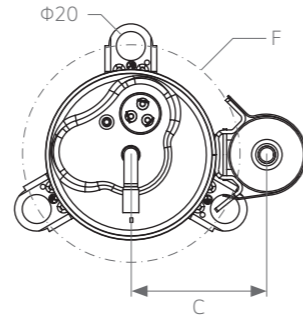

· DKT / GKT-A

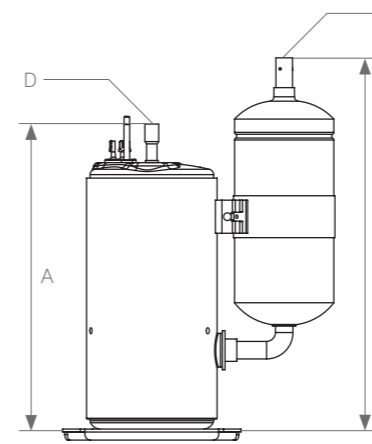
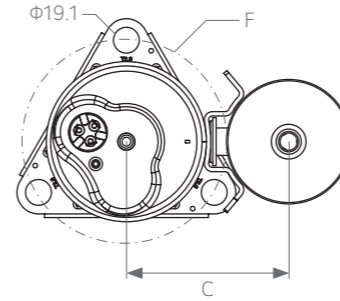

· DKT / GKT-B

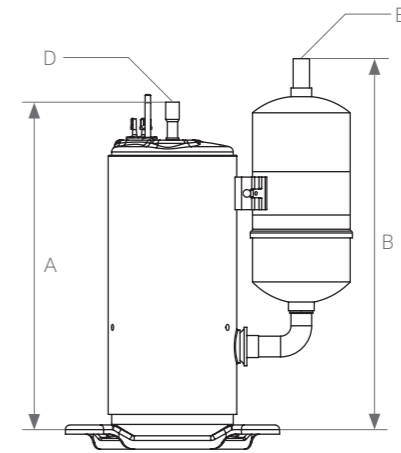
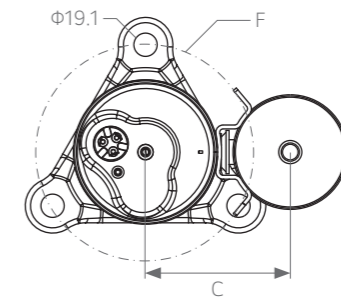

· DKT / GKT-C

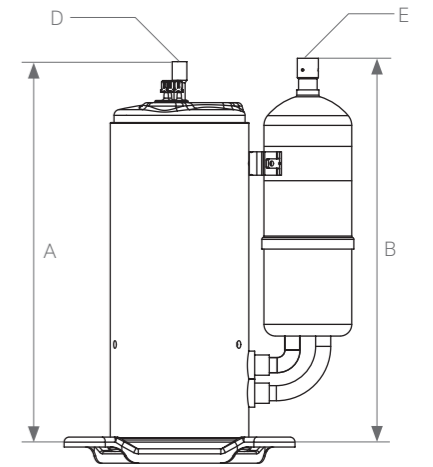
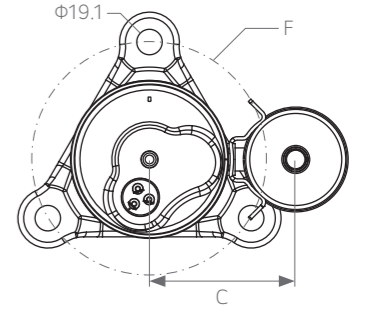

Model	Series	Dimension					
		A	B	C	D	E	F
EST092MB	EST	220.6	225.3	66.7	8.06	9.7	150
EST102MB	EST	220.6	225.3	66.7	8.06	9.7	150
PST066MA	PST	218.6	211.3	66.7	8.06	9.7	130
PST092MA	PST	198.6	191.3	66.7	8.06	9.7	130
PST102MA	PST	218.6	211.3	66.7	8.06	9.7	130
DAT134MC	DAT	293.2	306.3	99.6	8.06	12.8	176
GAT134MC	GAT	292.9	305.9	99.6	8.06	12.8	176
DAT156MA	DAT	292.9	305.9	99.6	8.06	12.8	176
GAT156MA	GAT	292.9	312.9	96.1	8.06	12.8	176
GAT156MC	GAT	292.9	305.9	99.6	8.06	12.8	176
PAT134MA	PAT	249.0	239.0	81.0	8.06	9.7	150

Model	Series	Dimension					
		A	B	C	D	E	F
DKT141MB	DKT-A	318.0	346.0	118.7	9.7	12.8	150
DKT176MA	DKT-B	320.0	355.6	118.7	9.7	12.8	176
DKT176MD	DKT-C	320.0	325.6	109.6	9.7	16.0	176
DKT208MA	DKT-B	299.5	339.5	118.7	9.7	12.8	176
DKT208MC	DKT-C	331.0	336.6	109.6	9.7	16.0	176
GKT141MB	GKT-A	318.0	346.0	120.0	9.7	12.8	150
GKT176MA	GKT-B	320.0	328.8	120.0	9.7	12.8	176
GKT176MB	GKT-B	279.5	339.5	118.7	9.7	12.8	176
GKT208MA	GKT-B	299.5	346.5	109.6	9.7	12.8	176

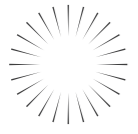

Outline Drawing for Variable Speed Model

· DKT / GKT-D

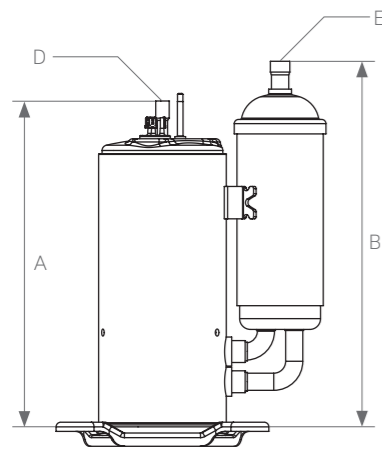
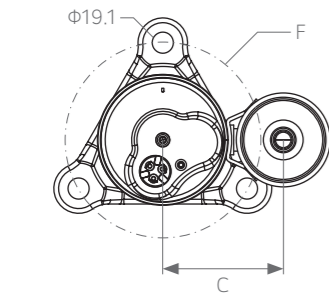

· DJT / GJT-A

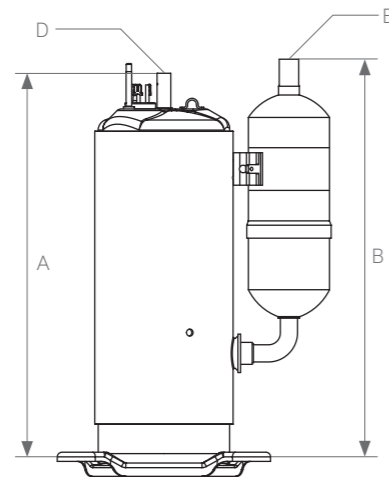
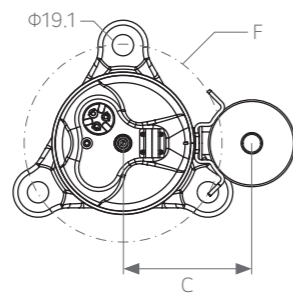

· DJT / GJT-B

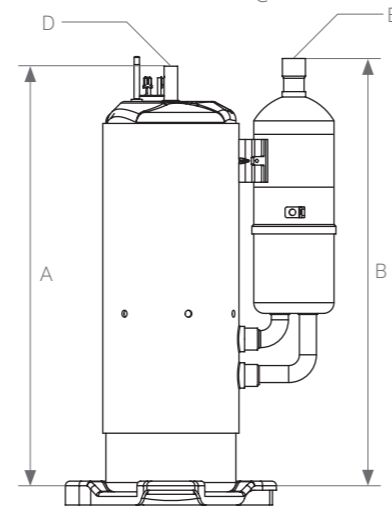
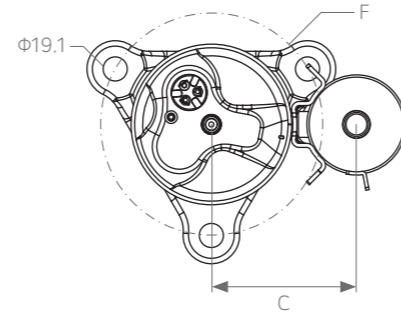

· DPT / GPT-V

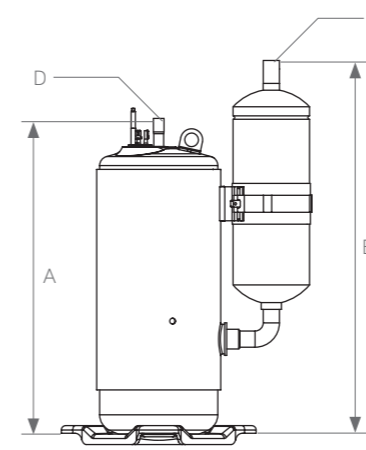
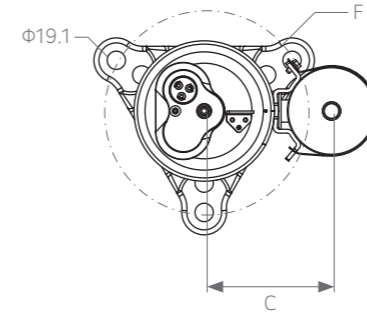

· GJT / KJT-U

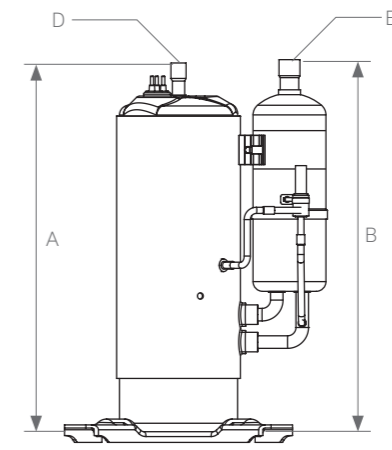
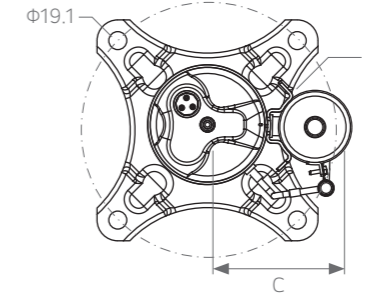

· GPT / KPT-U

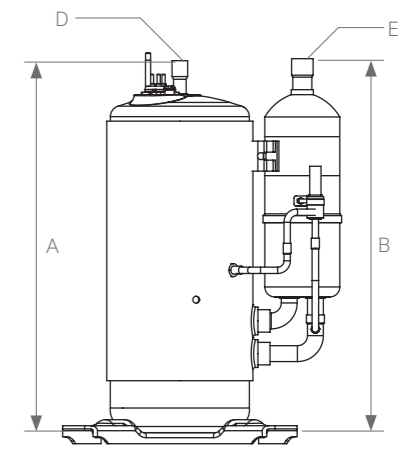
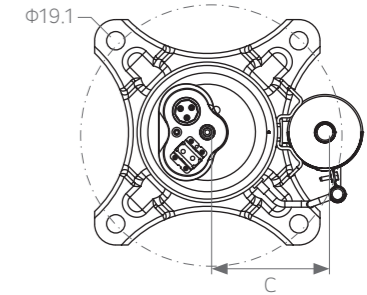

Model	Series	Dimension					
		A	B	C	D	E	F
DKT240MA	DKT-D	300.0	336.8	109.6	9.7	16.0	176
DKT240MB	DKT-D	323.5	336.8	109.6	9.7	16.0	176
DJT240MA	DJT-A	325.7	365.7	113.0	9.7	16.0	176
GJT240MA	GJT-A	352.7	365.7	113.0	9.7	16.0	176
DJT420MA	DJT-B	375.2	392.0	114.3	12.8	19.1	211

Model	Series	Dimension					
		A	B	C	D	E	F
GPT330MA	GPT-V	363.8	433.0	131.5	12.8	16.0	211
GPT442MA	GPT-V	363.8	429.8	131.5	12.8	16.0	211
DPT330MA	DPT-V	363.8	433.0	131.5	12.8	16.0	211
DPT442MA	DPT-V	363.8	429.8	131.5	12.8	16.0	211
DPT442MB	DPT-V	363.8	433.0	131.5	12.8	16.0	211
DPT442MC	DPT-V	353.9	432.1	131.5	12.8	16.0	176
GJT240MC	GJT-U	375.5	378.9	114.1	12.8	19.1	190.5
KJT240MC	KJT-U	375.5	378.9	114.1	12.8	19.1	190.5
GPT442MA	GPT-U	368.3	370.3	125.9	12.8	19.1	190.5
KPT442MA	KPT-U	368.3	370.3	125.9	12.8	19.1	190.5



Outline Drawing for Fixed Speed Model

· PSG

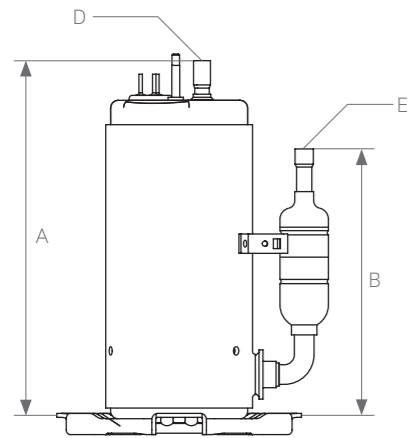
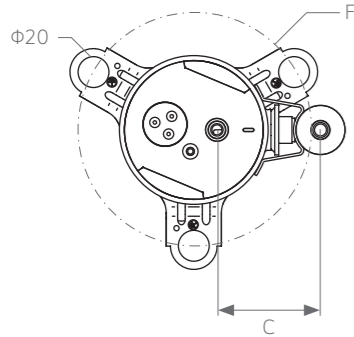

· DAB / GAB / EAB / GA / EA

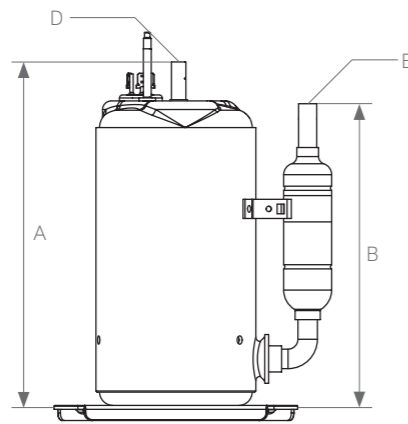
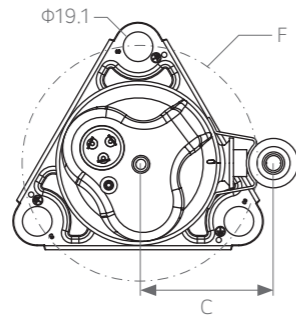

· PAB / PA

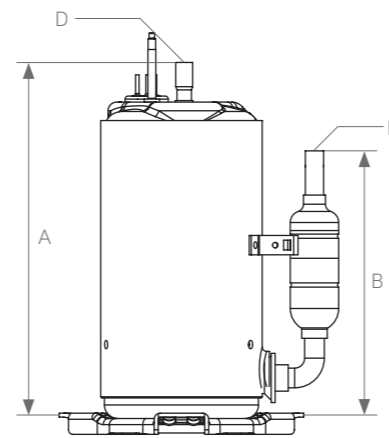
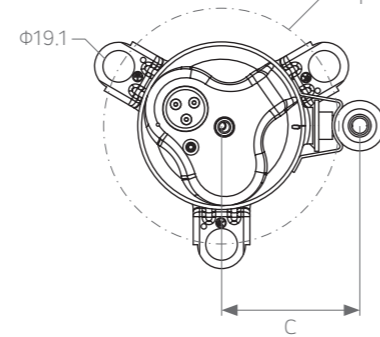

· DKN / GKN / DKS / GKS / EKS / GK-A

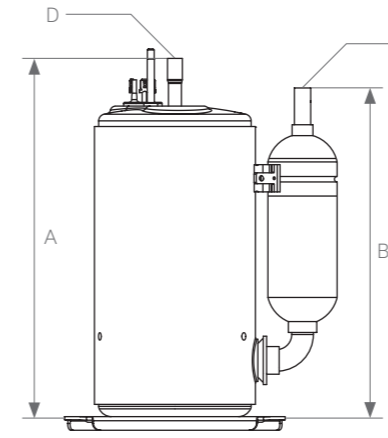
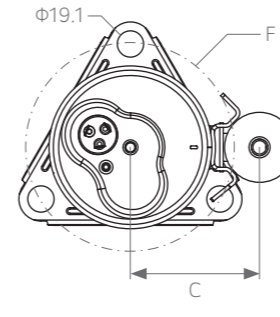

· DKN / GKN / DKS / GKS / GK-B

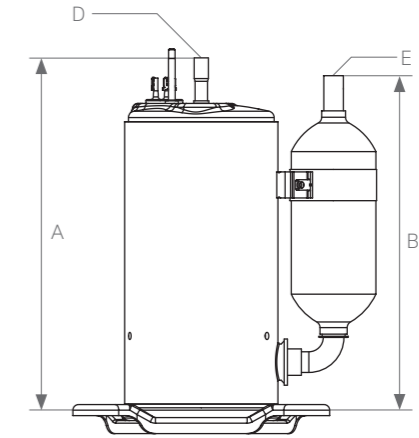
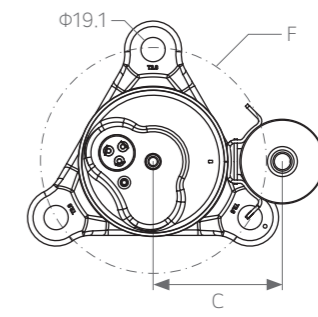

Model	Series	Dimension					
		A	B	C	D	E	F
PSG075KA	PSG	234.0	176.1	67.0	8.06	9.7	150
PSG075PA	PSG	234.0	176.1	67.0	8.06	9.7	150
PAB065PA	PAB	219.8	176.7	85.5	8.06	9.7	150
PAB086PA	PAB	234.9	228.7	85.5	8.06	9.7	150
DAB065CA	DAB	246.4	242.2	85.5	8.06	9.7	150
DAB080CA	DAB	246.4	212.2	85.5	8.06	12.8	150
DAB065KA	DAB	246.4	212.2	85.5	8.06	9.7	150
DAB080KA	DAB	246.4	212.2	85.5	8.06	12.8	150
GAB045CB	GAB	228.9	200.2	85.0	6.53	9.7	150
GAB046PA	GAB	251.7	258.9	85.6	8.06	9.7	150
GAB050CA	GAB	236.2	197.2	85.0	6.53	9.7	150
GAB070CB	GAB	246.4	229.2	85.5	6.53	9.7	150
GAB070KA	GAB	249.9	232.2	85.5	8.06	9.7	150
EA078PA	EA	225.3	182.2	85.5	8.06	9.7	150
EA089PA	EA	229.7	199.9	85.5	8.06	9.7	150
GA066QA	GA	250.7	239.2	85.5	8.06	9.7	150
GA066CA	GA	251.7	238.9	89.0	8.06	9.7	150
GA066KA	GA	250.7	239.2	85.5	8.06	9.7	150
PA125PA	PA	245.4	232.7	85.5	8.06	9.7	150
EAB086KA	EAB	256.2	224.2	98.0	6.5	9.7	150

Model	Series	Dimension					
		A	B	C	D	E	F
GKN102PA	GKN-A	253.9	218.9	93.5	8.06	9.7	150
DKS108CA	DKS-A	274.8	259.9	93.0	8.06	12.8	150
DKS126CA	DKS-A	273.9	258.9	93.5	8.06	12.8	150
DKN127KA	DKN-A	273.9	263.9	103.5	8.06	12.8	150
GKN127PA	GKN-A	282.9	263.9	103.0	8.06	9.7	150
GKN141PA	GKN-A	285.5	264.9	103.0	8.06	12.8	150
GK080CA	GK-B	262.3	253.6	103.0	8.06	12.8	176
GK080QA	GK-B	254.3	253.6	103.0	8.06	12.8	176
EKS094KA	EKS-A	240.0	208.0	93.0	8.06	9.7	150
GKS086KA	GKS-B	269.3	251.6	103.0	8.06	12.8	176
GKS086QA	GKS-B	259.3	251.6	103.0	8.06	12.8	176
GKS102KA	GKS-B	259.3	251.6	103.0	8.06	12.8	176
GKS102QA	GKS-B	259.3	251.6	103.0	8.06	12.8	176
GKS108CB	GKS-B	265.6	289.9	103.0	8.06	12.8	176
GKS113KA	GKS-B	269.3	251.6	103.0	8.06	12.8	176
GKS113CA	GKS-B	259.3	251.6	103.0	8.06	12.8	176
GKS113QA	GKS-B	259.3	251.6	104.0	8.06	12.8	176
GKS120QA	GKS-B	259.3	251.6	104.0	8.06	12.8	176
DKN127PA	DKN-B	268.6	254.9	103.0	8.06	12.8	176

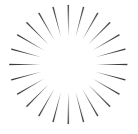

Outline Drawing for Fixed Speed Model

· DKN / GKN / DKS / GKS / GK-B · DKN / GKN / DKS / GKS / GK-C · DJS / GJS / QJS / GJ

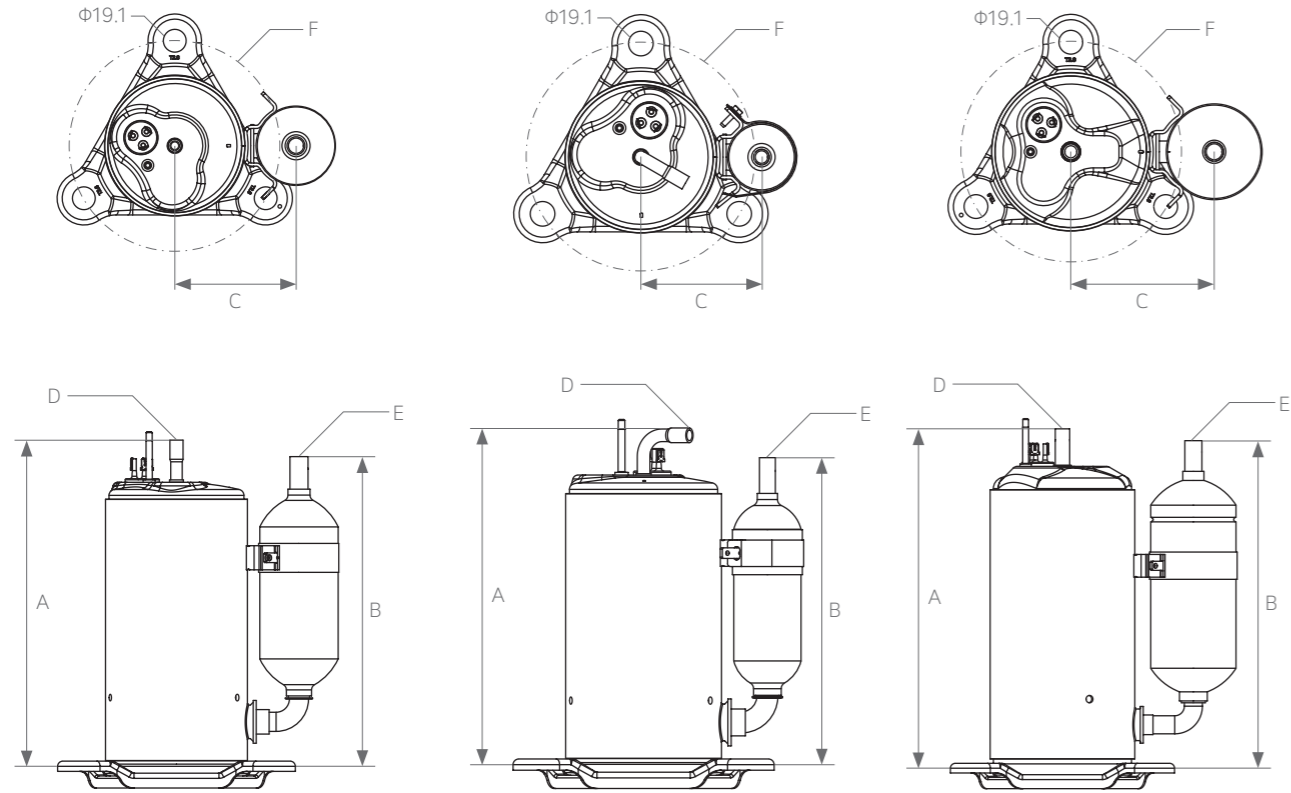

Model	Series	Dimension					
		A	B	C	D	E	F
GKS134KA	GKS-B	263.6	254.9	104.0	8.06	12.8	176
GKS134CA	GKS-B	263.0	253.6	103.0	8.06	12.8	176
GKS141KA	GKS-B	263.0	263.0	109.0	8.06	12.8	176
GKS141QA	GKS-B	273.3	253.6	103.0	8.06	12.8	176
GKS134CM	GKS-C	270.3	233.6	93.0	8.06	9.7	176
DKN141PA	DKN-B	268.6	254.9	103.0	8.06	12.8	176
GK151KA	GK-B	278.6	262.6	109.0	9.7	12.8	176
GK151QA	GK-B	272.3	262.6	109.0	9.7	12.8	176
GKN102CM	GKN-C	253.2	229.9	93.0	8.06	9.7	176
GKN141CM	GKN-C	253.2	229.9	93.0	8.06	9.7	176
GJS151KA	GJS	286.6	266.0	113.0	9.7	12.8	176
DJS165PA	DJS	301.6	288.2	115.0	9.7	12.8	176
GJS176QA	GJS	287.0	266.0	115.0	9.7	12.8	176
DJS189PA	DJS	301.6	286.2	115.0	9.7	12.8	176
DJS230PA	DJS	301.6	319.2	115.0	9.7	12.8	176
GJ230KA	GJ	315.3	286.9	113.0	9.7	12.8	176
GJS208KA	GJS	297.6	266.3	113.0	9.7	12.8	176
GJS208PA	GJS	298.8	268.2	113.8	9.7	12.8	176
GJS222PA	GJS	297.2	320.0	113.8	9.7	12.8	176

· DJS / GJS / QJS / GJ

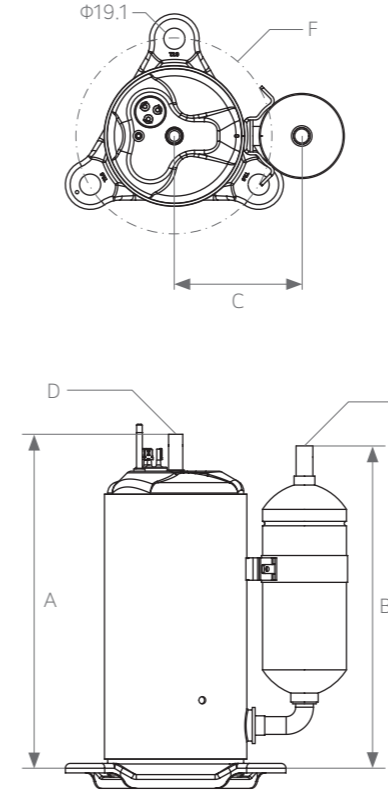

Model	Series	Dimension					
		A	B	C	D	E	F
GJS160KA	GJS	303.1	308.2	113.8	9.7	12.8	176
GJS176KA	GJS	287.0	266.0	115.0	9.7	12.8	176
GJS160KB	GJS	303.1	286.2	113.8	9.7	12.8	176
GJS176KB	GJS	311.6	286.2	113.8	9.7	16.0	176
QJS222PM	QJS	290.6	256.2	109.0	9.7	12.8	176
QJS258KM	QJS	299.3	263.3	106.0	9.7	12.8	176
QJS282KA	QJS	309.3	297.2	113.0	9.7	12.8	176
GJS134CA	GJS-B	222.3	190.5	113.0	8.06	9.7	176
GJS134PA	GJS-B	215.3	190.5	113.0	8.06	9.7	176
DVH151KA	DVH	333.8	300.7	119.0	9.7	16.0	176
GVH180PA	GVH	326.6	336.7	120.0	9.7	16.0	176
GVH198KA	GVH	341.8	316.7	120.1	9.7	16.0	176
DVH218KA	DVH	333.8	333.7	119.0	9.7	16.0	176
DVH240PA	DVH	341.8	336.7	120.1	9.7	16.0	176
GVH240KA	GVH	346.8	316.7	120.1	9.7	16.0	176
GVH240PA	GVH	341.8	336.7	120.1	9.7	16.0	176
GVH250PA	GVH	331.6	336.7	120.0	9.7	16.0	176
GVH265PA	GVH	323.6	333.7	120.1	9.7	16.0	176
GVH282PA	GVH	366.8	340.2	128.5	9.7	16.0	176

· DVH / GVH / DVS / GVS

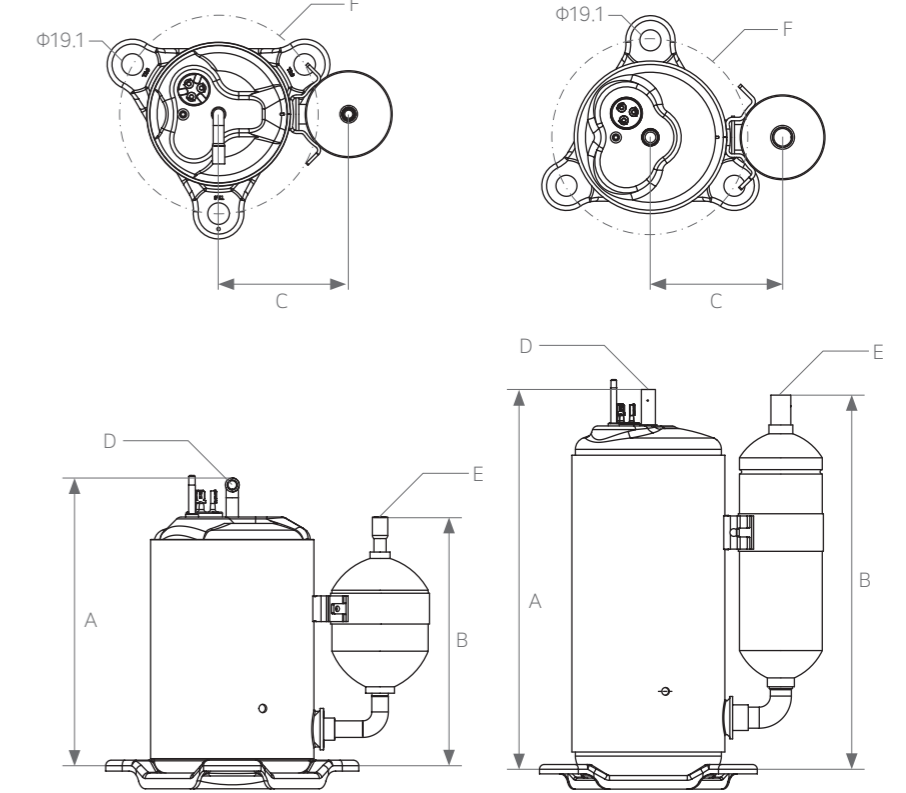

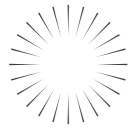

Outline Drawing for Fixed Speed Model

· DVH / GVH / DVS / GVS

· QVS

· QP

· GPT-F

· GJA / KJA

· GVA / KVA

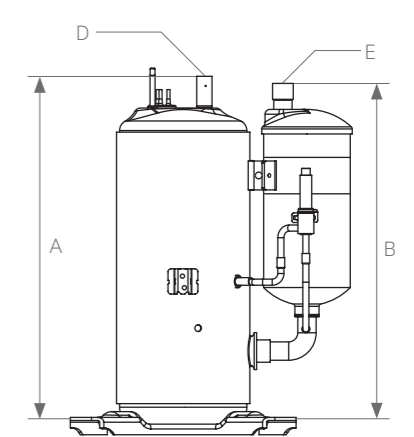
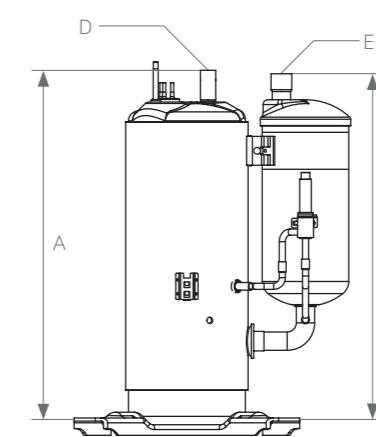
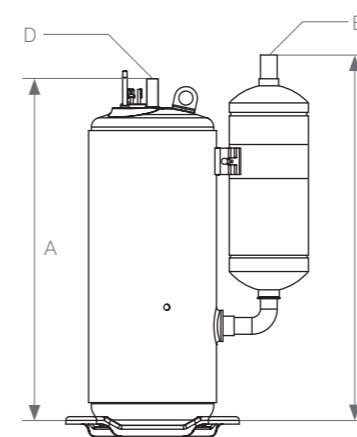
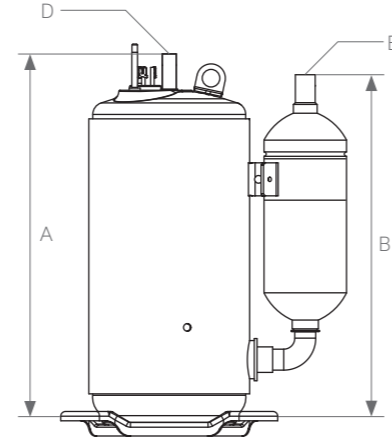
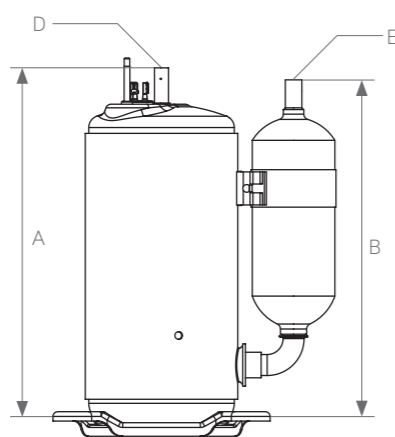
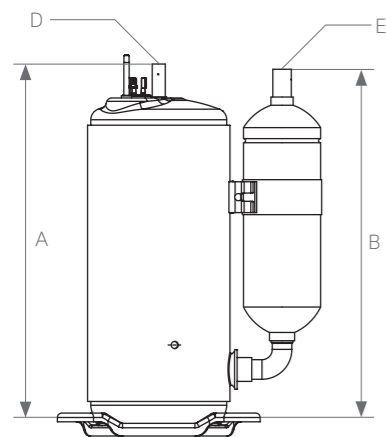
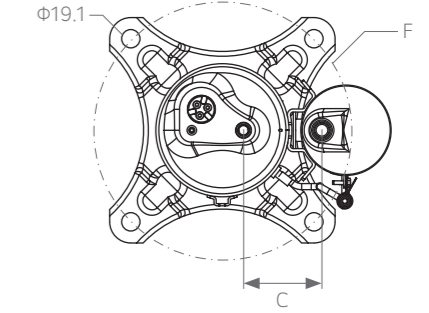
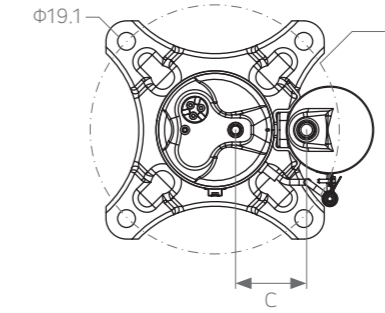
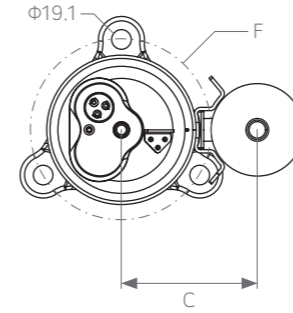
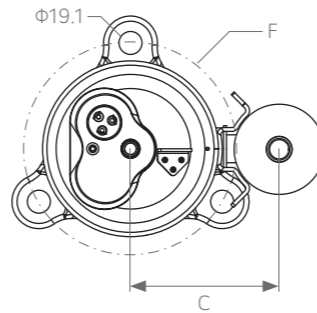
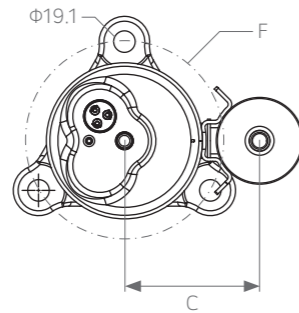
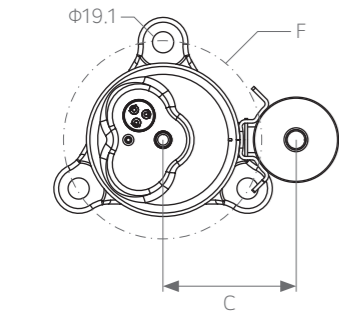

Model	Series	Dimension					
		A	B	C	D	E	F
GVS215KA	GVS	341.7	315.8	128.4	9.7	16.0	176
GVS265KA	GVS	346.7	351.8	128.4	9.7	16.0	176
GVS265PA	GVS	351.7	335.8	120.1	9.7	16.0	176
GVS295PA	GVS	341.7	351.8	128.4	9.7	16.0	176
GVS325PA	GVS	349.8	352.7	128.5	9.7	16.0	176
GVS215KB	GVS	334.6	303.7	120.1	9.7	16.0	176
GVS295QM	GVS	334.6	339.0	120.0	9.7	16.0	176
DVS295PA	DVS	339.8	336.7	120.1	9.7	16.0	176
DVS325PA	DVS	349.8	352.7	128.5	9.7	16.0	176
QVS250KA	QVS	329.6	316.7	120.0	9.7	16.0	176
QVS348KM	QVS	334.6	336.7	120.0	9.7	16.0	176
QVS325PA	QVS	314.6	303.7	120.0	9.7	12.8	176
QP407PA	QP	328.0	312.0	123.4	9.7	16.0	176
QP442PB	QP	326.5	345.3	123.9	9.7	16.0	176
QP464PA	QP	328.0	345.0	123.4	9.7	16.0	176
QP464PB	QP	328.0	345.0	123.4	9.7	16.0	176

Model	Series	Dimension					
		A	B	C	D	E	F
GPT342KA	GPT-F	389.0	415.4	132.3	9.7	16.0	176
GPT362KA	GPT-F	367.7	405.1	132.3	9.7	16.0	176
KJA104KA	KJA	331.5	339.1	123.4	12.8	19.1	190.5
KJA151KA	KJA	336.6	339.1	123.4	12.8	19.1	190.5
KJA200KA	KJA	365.0	360.4	98.3	12.8	19.1	190.5
GVA153KA	GVA	352.5	350.1	106.4	12.8	19.1	190.5
GVA198KA	GVA	352.5	350.1	106.4	12.8	19.1	190.5
GVA202KA	GVA	352.5	350.1	106.4	12.8	19.1	190.5
GVA236KA	GVA	357.5	350.1	106.4	12.8	19.1	190.5
GVA250KA	GVA	357.5	350.1	106.4	12.8	19.1	190.5
KVA236KA	KVA	357.6	350.0	103.9	12.8	19.1	190.5
KVA250KA	KVA	357.6	350.0	103.9	12.8	19.1	190.5
KVA282KA	KVA	357.6	350.0	103.9	12.8	19.1	190.5

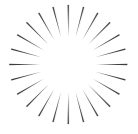

Accessories

Wiring Diagram

For External O.L.P

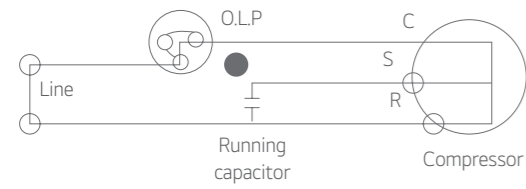

For Internal O.L.P

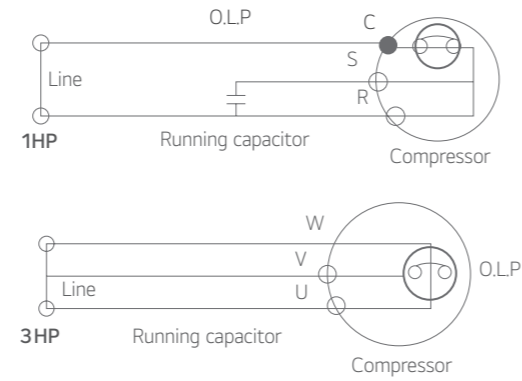

Cover Terminal Fitting

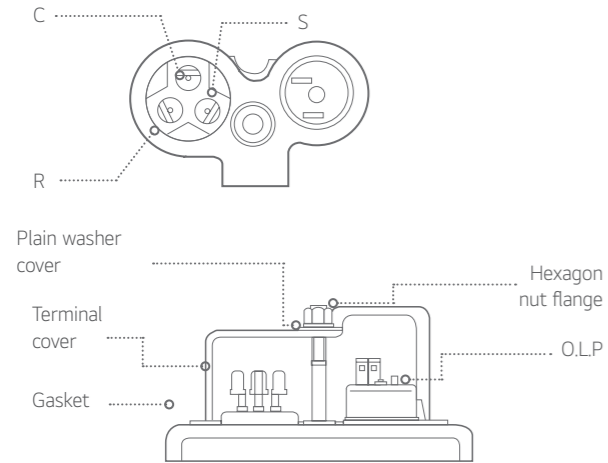

*O.L.P : Over Load Protector

Cover Terminal Fitting

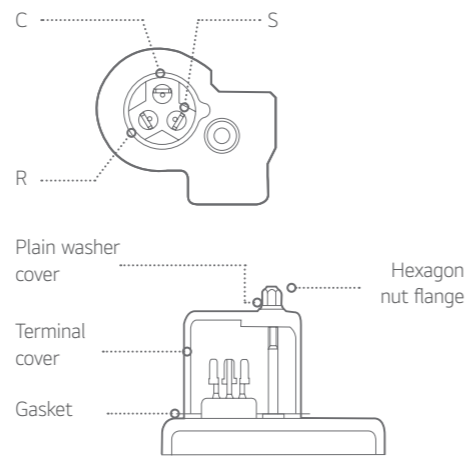

Mounting

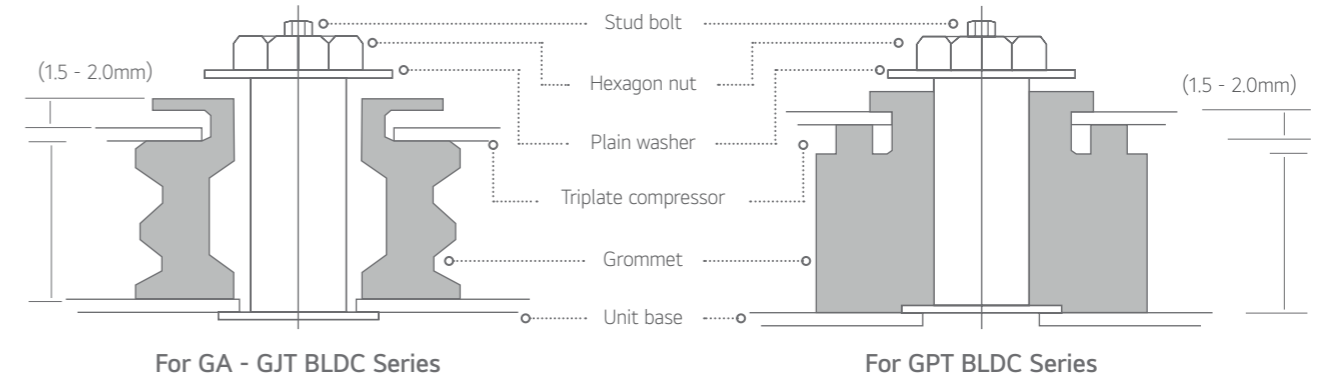

Accessory Parts

Accessory	Terminal cover		Gasket		Plain washer		Nut		Stud bolt	Grommet		
	①	②	③	④	⑤	⑪	⑥	⑫	⑩	⑦	⑧	⑨
Internal OLP Fixed Speed Model / Variable Speed	●		●		●	●	●	●	●	●	●	●
External OLP Fixed Speed Model		●		●	●	●	●	●	●	●	●	●

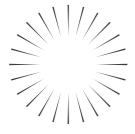

Accessories

Packing & Container Stuffing Quantity

Korea

Items	1 Step pallet			2 Steps pallet			3 Step pallet			1 Container (20ft)					
	Packing quantity	Size		Packing quantity	Size		Packing quantity	Size		Packing quantity	Pallet quantity				
		A	B		A	B		A	B		Step 1	Step 2	Step 3	Accessory	Total
GPT	16	1,150	600	32	1,150	1,000	0	1,150	0	640	0	20	0	0	20
GJT	16	1,150	500	32	1,150	900	0	1,150	0	640	0	20	0	0	20

China

Items	1 Step pallet			2 Steps pallet			3 Step pallet			1 Container (20ft)					
	Packing quantity	Size		Packing quantity	Size		Packing quantity	Size		Packing quantity	Pallet quantity				
		A	B		A	B		A	B		Step 1	Step 2	Step 3	Accessory	Total
DSG	30	960	449	60	960	758	90	960	1,066	1,740	12	23	0	1	36
DXT	36	960	453	72	960	765	108	960	1,078	2,484	0	0	23	1	24
EXT	36	960	411	72	960	682	108	960	953	2,484	0	0	23	1	24
DST	30	960	446	60	960	752	90	960	1,058	2,070	0	0	23	1	24
EST	36	960	396	72	960	652	108	960	908	2,484	0	0	23	1	24
PST	36	960	396	72	960	652	108	960	908	2,484	0	0	23	1	24
PSG	36	960	446	72	960	752	108	960	1,059	1,656	0	23	0	1	24
DAB	36	960	409	72	960	678	108	960	948	2,484	0	0	23	1	24
GAB	30	960	428	60	960	716	90	960	1,004	1,080	0	0	12	1	13
EAB	30	960	439	60	960	738	90	960	1,037	1,380	0	23	0	1	24
GAB	30	960	428	60	960	716	90	960	1,004	1,080	0	0	12	1	13
PAB	36	960	401	72	960	662	108	960	923	1,656	0	23	0	1	24
PA	30	960	432	60	960	723	90	960	1,015	1,380	0	23	0	1	24
DKN	30	960	453	60	960	766	90	960	476	1,380	0	23	0	1	24
DKS	30	960	444	60	960	748	90	960	1,052	1,380	0	23	0	1	24
QJS	20	960	474	40	960	808	0	960	0	920	0	23	0	1	24
GJS	20	960	469	40	960	798	0	960	0	920	0	23	0	1	24
DVH	20	960	518	40	960	895	0	960	0	920	0	23	0	1	24
GVS	20	960	529	40	960	917	0	960	0	920	0	23	0	1	24
QVS	20	960	529	40	960	917	0	960	0	920	0	23	0	1	24
GPT-F	16	960	569	0	960	0	0	960	0	560	35	0	0	1	36
GKS	30	960	460	60	960	780	0	960	0	1,380	0	23	0	1	24
GKN	30	960	445	60	960	750	0	960	0	1,380	0	23	0	1	24

Thailand

Items	1 Step pallet			2 Steps pallet			3 Step pallet			1 Container (20ft)					
	Packing quantity	Size		Packing quantity	Size		Packing quantity	Size		Packing quantity	Pallet quantity				
		A	B		A	B		A	B		Step 1	Step 2	Step 3	Accessory	Total
DSG	42	1,150	340	84	1,150	703	0	1,150	0	1,140	0	19	0	1	20
DST	42	1,150	370	84	1,150	763	0	1,150	0	1,596	0	19	0	1	20
DKN	25	1,150	379	50	1,150	779	0	1,150	0	1,200	10	19	0	1	30
DKS	25	1,150	373	50	1,150	767	0	1,150	0	1,200	10	19	0	1	30
DJS	25	1,150	425	50	1,150	871	0	1,150	0	950	0	19	0	1	20
GJS-B	25	1,150	354	50	1,150	729	0	1,150	0	950	0	19	0	1	20
QJS	25	1,150	410	50	1,150	841	0	1,150	0	950	0	19	0	1	20
GVH	25	1,150	459	50	1,150	940	0	1,150	0	800	0	16	0	1	17
DVS	25	1,150	457	50	1,150	936	0	1,150	0	800	0	16	0	1	17
GVS	25	1,150	457	50	1,150	936	0	1,150	0	800	0	16	0	1	17
QVS	25	1,150	447	50	1,150	915	0	1,150	0	800	0	16	0	1	17
GVA	16	1,150	473	32	1,150	969	0	1,150	0	640	0	20	0	1	21
GKS	25	1,150	379	50	1,150	779	0	1,150	0	1,200	10	19	0	1	30
GKN	25	1,150	362	50	1,150	746	0	1,150	0	1,200	10	19	0	1	30

Note 1 : Packing conditions are subjects to change without notice.

Note 2 : Please inquire about series not listed.

1 Step Pallet

